

HOW TO REPLACE THE HEAD OF A NIKKEN NPU DRILL CHUCK

Changing a Drill Chuck Head

1. Remove pull stud from holder.
2. Turn cap bolt (A) CCW 1 full turn.
3. Put spacer (B) into pull stud hole (spacer size varies per tool).
4. Put pull stud back in holder and tighten until drill chuck disengages from holder at taper contact (C).
5. Remove pull stud, spacer, cap bolt and drill chuck head from holder.
6. Replace NPU head.

Tightening torque:

NPU8: 9 ft.lbs. NPU13: 12ft.lbs.

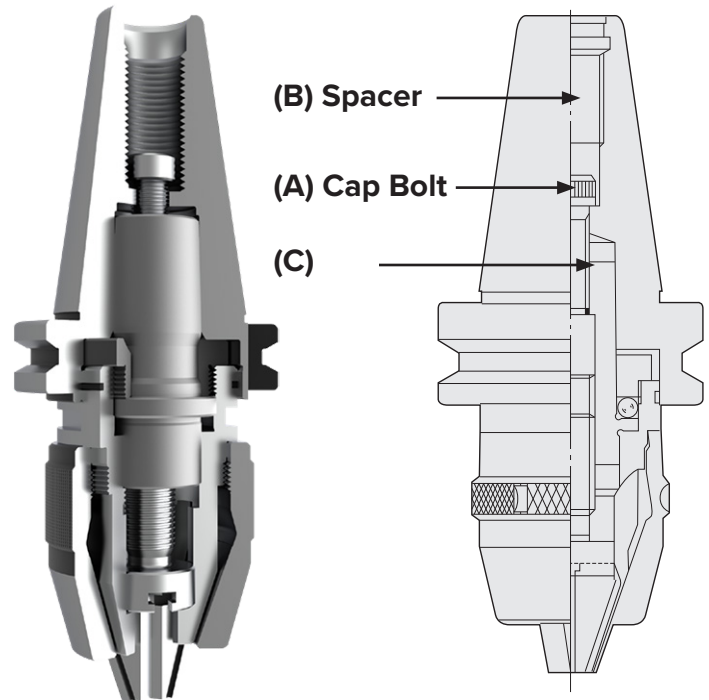

Changing Jaws on a Drill Chuck Head

1. After drill chuck head is removed from holder, take o-ring out from head.
 2. Put the head in scroll chuck by holding part (D).
 3. Turn part (E) CCW with wrench until cap comes off.
- * If cap doesn't turn, heat the head to dissolve the lock-tite inside.

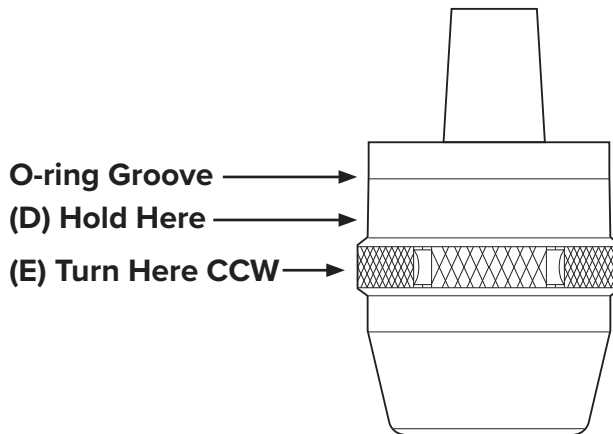

PARTS FOR NPU

Only jaws (3 pcs./set) and head are available.

| JAWS | A | B | C | D |
|---------|------------|------------|-------------|------------|
| SP08061 | .114/2.9MM | .173/4.4MM | .374/9.5MM | .059/1.5MM |
| SP08062 | .114/2.9MM | .173/4.4MM | .409/10.4MM | .098/2.5MM |
| SP13060 | .118/3.0MM | .173/4.4MM | .484/12.3MM | .059/1.5MM |
| SP13061 | .134/3.4MM | .197/5.0MM | .484/12.3MM | .059/1.5MM |
| SP13062 | .134/3.4MM | .197/5.0MM | .524/13.3MM | .098/2.5MM |

